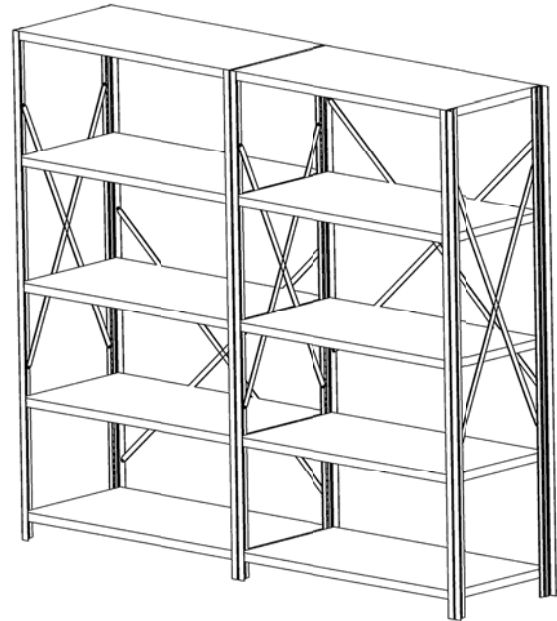
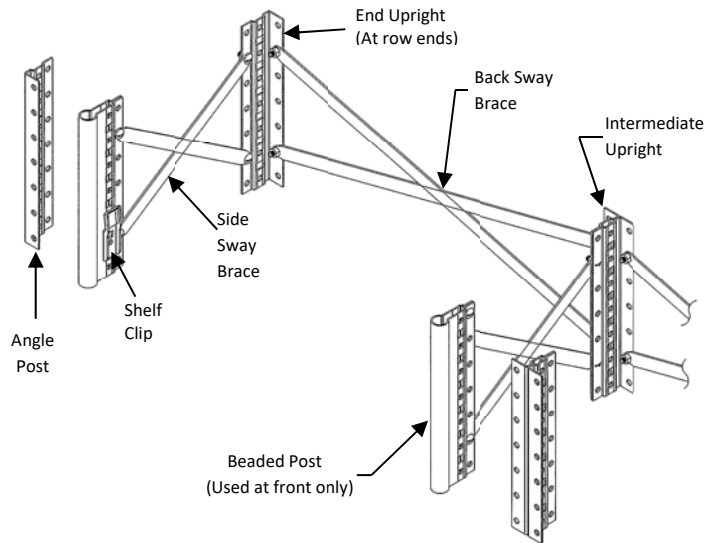

**OPEN UNIT ASSEMBLY**

1. The first and last uprights in a row of shelving are End Uprights. The remaining uprights in a row are Intermediate Uprights (see assembly graphic above). To build the End Upright, lay the front and rear posts parallel to each other on the floor or saw horses. Position Angle Posts with the 1" flange pointing up. The front post may be Beaded or Angle. The back post is always Angle.

Install Shelf Clips on both posts at the desired shelf locations by inserting the fingers of the clip into the rectangular holes in the post and sliding down until the clip is fully seated. Install the clips for the bottom shelf in the bottom two rectangular holes; install the clips for the top shelf in the top two rectangular holes.

Using a shelf to determine proper spacing of posts, attach a pair of Side Sway Braces to the posts forming an "X" with  $\frac{1}{4}$ -20 x  $\frac{5}{8}$ " screws and nuts. See page 3 for information regarding sway brace locations. Note: Bolts cannot be placed where shelves are located.

2. Intermediate Uprights are built like End Uprights, except Double Angle Posts replace Single Angle Posts (see graphic above). Double Angle Posts are made by bolting two Single Angle Posts together with two  $\frac{1}{4}$ -20 x  $\frac{5}{8}$ " screws and nuts. Install Shelf Clips on both sides of the post assembly. Attach a pair of Sway Braces to the front and rear posts as in Step 1.
3. Stand two End Uprights or an End and Intermediate Upright to build the first unit. Hold the uprights in position and install the top and bottom shelves onto the shelf clips. Make sure shelves are completely seated on the clips by tapping them down with a soft hammer. Repeat this process with the rest of the shelves in the first unit.
4. While holding the unit vertical, install a pair of Back Sway Braces in an "X" pattern using  $\frac{1}{4}$ -20 x  $\frac{5}{8}$ " screws and nuts. Attach the Back Sway Braces on the inside of the rear Angle Posts as shown.
5. If building a row of shelving, continue to add units by standing additional upright assemblies and installing shelves and back braces. The last upright in the row of shelving must be an End Upright.
6. Back to back (double) rows are built like single rows, except common Back Sway Braces are used. The common braces are installed on the inside of one of the units, with the bolts going through both rear posts of the back to back units. This will securely tie the back to back units together.

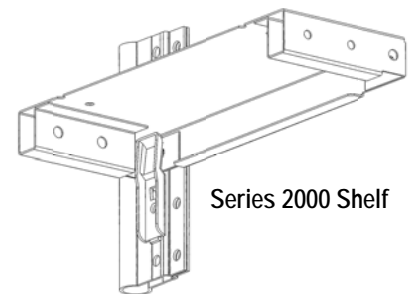
**Clip to Post Connection**

Series 2000 Shelf



**CLOSED UNIT ASSEMBLY**

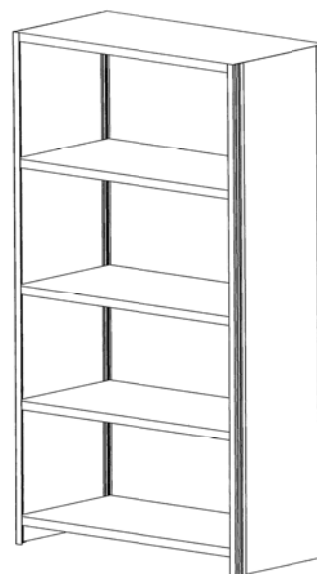
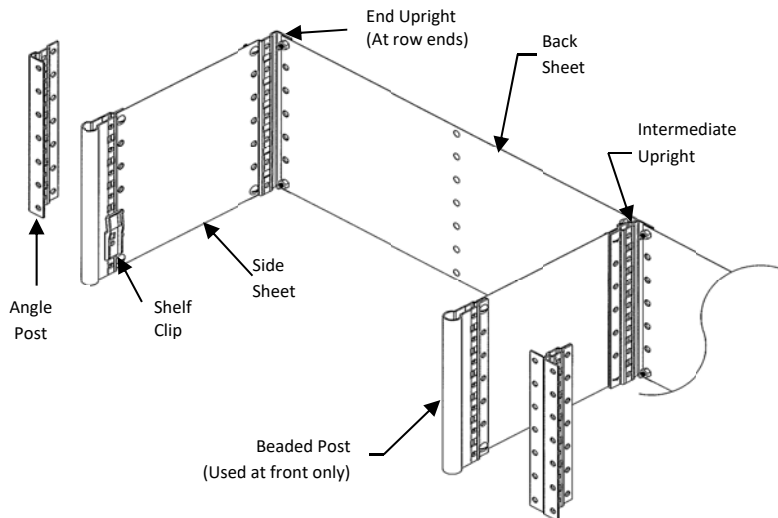

- The first and last uprights in a row of shelving are End Uprights. The remaining uprights in a row are Intermediate Uprights (see assembly graphic above). End and Intermediate Uprights are available in welded assemblies or may be built. To build, lay the front and rear post parallel to each other on the floor or saw horses. Position Angle Posts with the 1" flange pointing up. The front post may be Beaded or Angle. The back post is always Angle.

Install Shelf Clips on both posts at the desired shelf locations by inserting the fingers of the clip into the rectangular holes in the post and sliding down until the clip is fully seated. Install the clips for the bottom shelf in the bottom two rectangular holes; install the clips for the top shelf in the top two rectangular holes.

The Upright Side Sheet is attached to the side of the Angle or Beaded post as shown using 1/4- 20 x 5/8" Truss Head screws and nuts. Upright Sheets are supplied with two screws and nuts for every foot of height. Note: Bolts cannot be placed where shelves are located.

- Intermediate Uprights are built like End Uprights, except Double Angle Posts replace Single Angle Posts (see graphic above). Double Angle Posts are made by bolting two Single Angle Posts together with two 1/4-20 x 5/8" screws and nuts. Install shelf clips on both sides of the post assembly. The Upright Side Sheet is bolted to the side of the Double Angle Posts with 1/4-20 x 5/8" Truss Head screws and nuts.

If a Beaded Post is used, attach the Upright Side Sheet to the side of the Beaded Post with 1/4-20 x 5/8" Truss Head screws and nuts.

- Stand two End Uprights or an End and Intermediate Upright to build the first unit. Hold the uprights in position and install the top and bottom Shelves on to the shelf clips. Make sure shelves are completely seated on the clips by tapping them down with a soft hammer. Repeat this process with the rest of the shelves in the first unit.
- While holding the unit vertical, install a Back Sheet using 1/4-20 x 5/8" screws and nuts. Attach the Back Sheet to the inside of the rear angle posts as shown. Slide one edge of the sheet between the shelf and post; then slide the other edge bowing the Back Sheet as needed. Line up the holes in the post with holes in the back and bolt in place using 1/4-20 x 5/8" Truss Head screws and nuts. Note: Bolts cannot be placed where shelves are located. Bolt backs according to number of bolts and spacing shown below.

Height of Closed Back	Total Number of Bolts and Nuts	Maximum Bolt Spacing
To 3' 11-1/2"	4	46-1/2"
4'1" to 5'11-1/2"	6	36"
6'1" to 7'11-1/2"	8	31-1/2"
8'1" to 9'-11-1/2"	10	30"

- If building a row of shelving, continue to add units by standing additional uprights and installing shelves and backs. The last upright in a row is an end upright.
- Back to back (double) rows are built like single rows, except common backs are used. The common Back Sheet is installed on the inside of one of the units, with the bolts going through both rear posts of the back to back units. This will securely tie the back to back units together.

**Welded Upright Assemblies – top view**

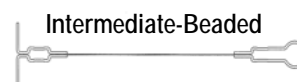

**SWAY BRACING PATTERNS** – NOTE: Bracing patterns represent the minimum bracing required for units 8'-1" high and under in Seismic Zone 0.

**Back and Side Bracing – Top**

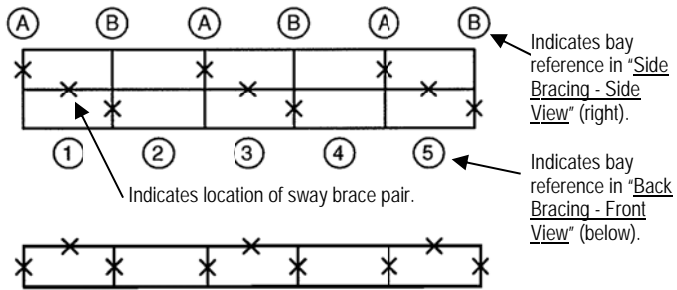

**Side Bracing – Side View**

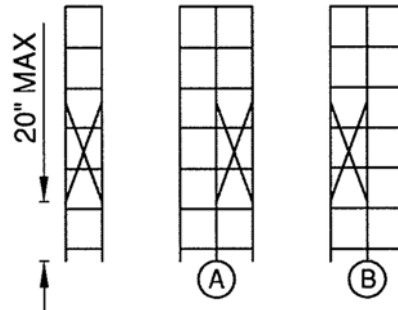

**Back Bracing – Front View**

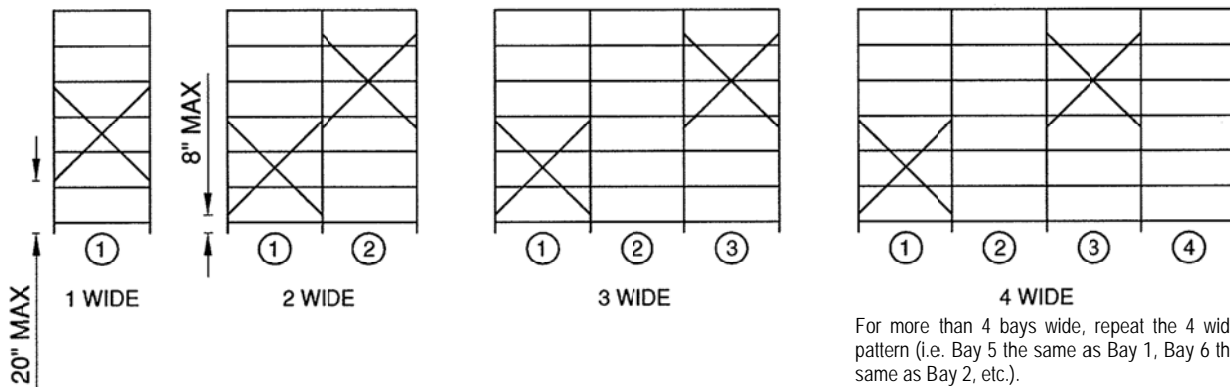

**Unit Detail for Back and Side Bracing – Top View**

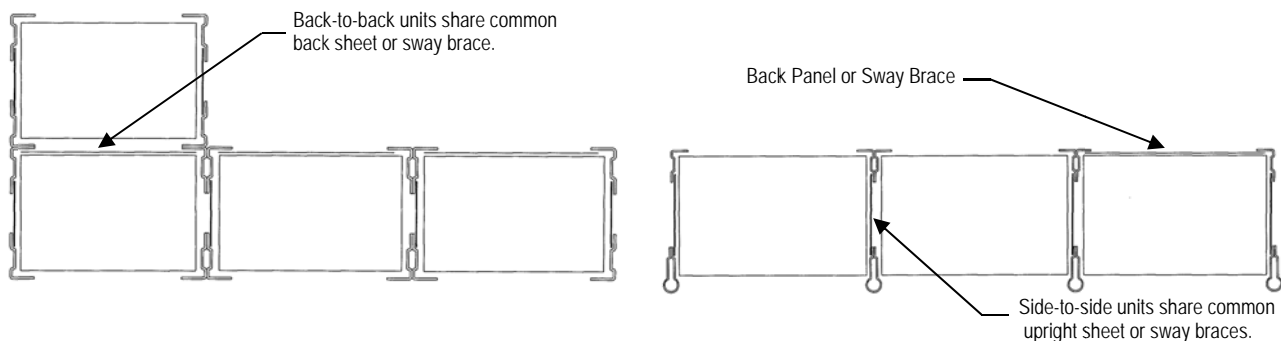

**SHELVING ACCESSORIES**

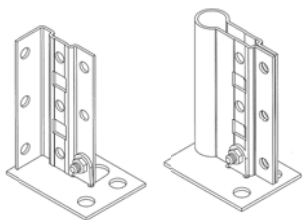

**Foot Plate – Angle and Beaded Post**  
 Attach Angle Post with ¼-20 x 5/8" truss head screw and nut. Attach Beaded Post with ¼-20 x 1" truss head screw and nut. Floor anchors are not supplied with foot plates.

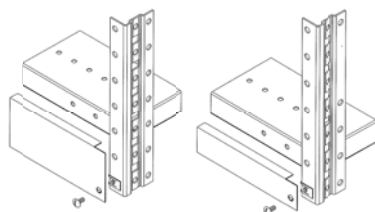

**Front Base - Angle Post**  
 Attach to Angle Post with Tinnerman Nuts #702517 and #10 x 5/16" truss head sheet metal screws. Half Shelf Clips are furnished with 1-1/2" bases.

Half Shelf Clips

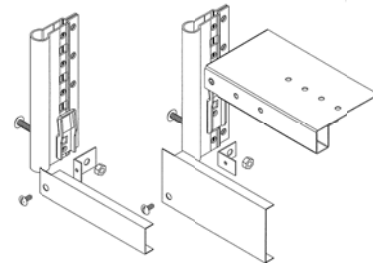
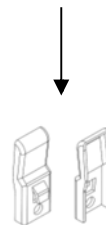

**Front Base – Beaded Post**  
 Attach 1-1/2" base with #198743 base clips, ¼-20 x 1-1/2" truss head screws, nuts and #10 x ½" long sheet metal screws. Attach 3" base with #198742 base clips, ¼-20 x 1" truss head screws, nuts and #10 x ½" long sheet metal screws. Half shelf clips are used with 1-1/2" front bases.

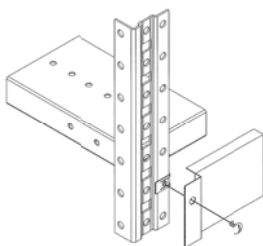

**End Base**  
 Attach to posts with Tinnerman Nuts #702517 and #10 x 1/2" truss head sheet metal screws.

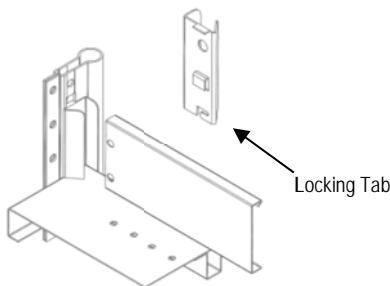

**Universal Bin Front**  
 Insert right and left hand clips into Beaded or Angle Post directly above shelf. Bend locking tab at bottom of clip into rectangle in post.

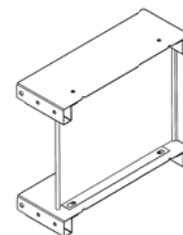

**Shelf Divider**  
 Attach to Series 2000 shelf with #701487 Plastic Panel Clips. When installed, front edge of divider is 5/8" back from front edge of shelf.

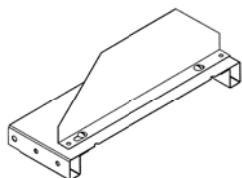

**Angle Divider**  
 Attach to Series 2000 shelf with #12-24 x 3/8" truss head screws and nuts.

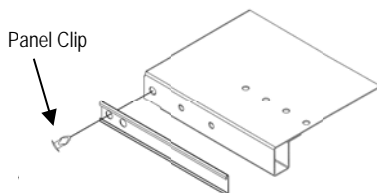

**Label Holder**  
 Attach to Series 2000 Shelf with #701487 Panel Clips.